



Atwood Mobile Products
 4750 Hiawatha Drive • Rockford, IL 61103-1298
 PHONE: 815•877•5700 FAX: 815•877•7469
 INTERNET: <http://www.atwoodmobile.com>



MPD 93756

**L.P. GAS
 WATER HEATER
 4 - 6 - 10 GALLON**

ENGLISH, FRANCAIS (et Canada)

•Installation •Operation •Maintenance

Effective 4/02/02

This water heater design has been certified by the Canadian Standards Association for installation in recreation vehicles. **This water heater is not for use in marine applications.**

SERVICE CALLS & QUESTIONS

Location and phone numbers of qualified Service Centers can be found at our website <http://www.atwoodmobile.com> or call 815-877-5700 to have a Service Center List mailed.

SAFETY ALERT SYMBOLS	
Safety Symbols alerting you to potential personal safety hazards. Obey all safety messages following these symbols.	
WARNING avoid possible injury or death	CAUTION avoid possible injury and/or property damage

Installation and service must be performed by a qualified Service Technician, Service Center, OEM or Gas Supplier.

WARNING FIRE OR EXPLOSION
<p>• If the information in this manual is not followed exactly, a fire or explosion may result causing property damage, personal injury or loss of life.</p> <p>► Do not store or use gasoline or other flammable vapors and liquids in the vicinity of this or any other appliance.</p> <p>WHAT TO DO IF YOU SMELL GAS</p> <ul style="list-style-type: none"> • Evacuate ALL persons from vehicle. • Shut off gas supply at gas container or source. • DO NOT touch any electrical switch, or use any phone or radio in vehicle. • DO NOT start vehicle's engine or electric generator. • Contact nearest gas supplier or qualified Service Technician for repairs. • If you cannot reach a gas supplier or qualified Service Technician, contact the nearest fire department. • DO NOT turn on gas supply until gas leak(s) has been repaired.

WATER HEATER MODEL IDENTIFICATION	1
DIMENSIONS	1
WEIGHT	1
SAFETY INFORMATION	2-4
Water Heater GENERAL INSTALLATION	2-3
Electronic Ignition wiring installation	
Pilot Relight wiring installation	
Heat Exchanger	
Combination Gas/Electric	
Water Heater PILOT OPERATION	3-4
Electronic Ignition	
Pilot Relight	
Combination Gas/Electric	
Water Heater MAINTENANCE	4-5
Electronic Ignition	
Electric	
FIGURES 1-11	6
WIRING DIAGRAMS	7
PART IDENTIFICATION	8-9
Water Heater WARRANTY	16

EXPLANATION OF MODEL NUMBER (EXAMPLE)

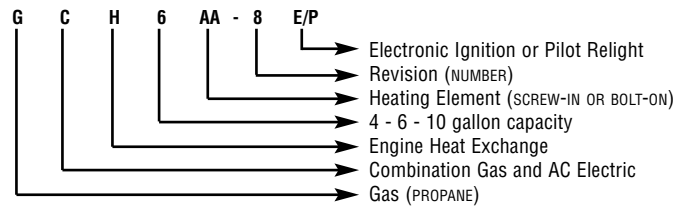

- IF YOUR MODEL NUMBER IS NOT LISTED-
 Older revision numbers may be 3, 4, 6, 7, 8 or 9 (_ _ _ _ _ X _)

Regardless of your revision number the current instructions are still generally applicable to your unit. If you have questions contact your dealer, an Atwood Service Center or the Atwood Service Department.

MODEL NUMBER CLARIFICATION				
TYPE	4 GAL	6 GAL		10 GAL
Pilot Ignition	G4-7	G6A-7	GC6AA-8P	G10-2 GC10A-2
		GC6AA-8	GH6-7	G10-2P GC10A-2P
Electronic Ignition		G6A-8E	GCH6A-9E	G10-3E GCH10A-3E
		GC6AA-9E	GH6-8E	GC10A-3E GH10-3E
Pilot Relight	P IN MODEL # - SEE MODEL CLARIFICATION ABOVE			
Heat Exchange	H IN MODEL # - SEE MODEL CLARIFICATION ABOVE			
Electronic Ignition	E IN MODEL # - SEE MODEL CLARIFICATION ABOVE			
Combination Gas/Electric	C IN MODEL # - SEE MODEL CLARIFICATION ABOVE			
DIMENSIONS				SHIPPING WT.
ALL MODEL	WIDTH	HEIGHT		
6 GALLON	16"	12.5"		6 GALLON 25 lbs
10 GALLON	16"	15.5"		10 GALLON 32 lbs

CRITICAL INSTALLATION WARNINGS

- Install in recreation vehicles only. RV's are recreation vehicles designed as temporary living quarters for recreation, camping, or travel use having their own power or towed by another vehicle.
- All combustion air must be supplied from outside the RV, and all products of combustion must be vented to outside the RV.
- DO NOT vent water heater with venting system serving another appliance.
- DO NOT vent water heater to an outside enclosed porch area.
- Protect building materials from flue gas exhaust.
- Install water heater on an exterior wall, with access door opening to outdoors.
- DO NOT modify water heater in any way.
- DO NOT alter water heater for a positive grounding system.
- DO NOT HI-POT water heater unless electronic ignition system (circuit board) has been disconnected.
- DO NOT use battery charger to supply power to water heater even when testing.

- USA AND CANADA - FOLLOW ALL APPLICABLE STATE AND LOCAL CODES - IN THE ABSENCE OF LOCAL CODES OR REGULATIONS, REFER TO CURRENT STANDARDS OF:**
- Recreation Vehicles ANSI A119.2/NFPA 501C.
 - National Fuel Gas Code ANSI Z223.1 and/or CAN/CGA B149 Installation Codes
 - Federal Mobile Home Construction & Safety Standard, Title 24 CFR, part 3280, or when this Standard is not applicable, the Standard for Manufactured Home Installations (Manufactured Home Sites, Communities and Set-Ups), ANSI A255.1 and/or CAN/CSA-Z240 MH Series, Mobile Homes.
 - National Electrical Code ANSI/NFPA No. 70 and/or CSA C22.1
 - Park Trailers A119.5
 - CSA standard Z240 RV Series, Recreational Vehicle.

GENERAL INSTALLATION

Below is the most common type of installation for the water heater. However, there are other approved methods such as baggage compartment (refer to MPD 90093) and flush mounting installations (refer to MPD 93948). Consult your Field Auditor, Account Manager, or the Atwood Service Department if you have additional questions.

1. Locate water heater on floor of coach before erecting side walls. The water heater tank must be permanently supported at the same level as the bottom of sidewall cutout (by the floor or a raised floor).
2. To install water heater on carpeting, you must install appliance on a metal or wood panel that extends at least three inches beyond the full width and depth of appliance.
3. If water heater is installed where leakage of connections or tank will damage adjacent area, install a drain pan which can be drained to out side of coach, under water heater.
4. Connect both 1/2" NPT water lines - hot water outlet female (FIG 1-A) and cold water inlet female (FIG 1-B) and 3/8" flared LP gas lines (FIG 1-C).
 - a. Allow flexibility in water and gas lines so you can pull unit forward through wall one inch past skin (FIG 2).
 - b. Seal gas line entrance opening by sliding grommet (FIG 1-D) onto 3/8" tubing (FIG 1-F) before flaring tubing (FIG 1-F). Pull gas line and grommet through opening in housing (FIG 1-C). Connect flare fitting (FIG 1-E) and press grommet into opening. If gas line tubing is already flared, cut grommet on one side. Place split grommet over gas line and press it into opening.
 - c. Always use pipe lubricant on threads when connecting hot and cold water couplings. A suitable plastic fitting is recommended.

CAUTION **PRODUCT DAMAGE**

- Do not pull on main burner tube (FIG 9-C).

5. Erect side walls and cut opening. See chart and FIG 2-A & B. Frame with 2x2 lumber (or equivalent).

CUTOUT

CAPACITY	CUT OUT DIMENSION		DEPTH
Gallon	A	B	C
4 - 6	12-5/8"	16-1/4"	17-5/8"
10	15-3/4"	16-1/4"	20-5/8"

MINIMUM CLEARANCE FROM COMBUSTIBLE CONSTRUCTION

Sides:	0"	Top:	0"
Back:	0"	Bottom:	0"

6. Bend all flanges 90° along scored lines (FIG 3).
 7. To prevent water leaks caulk thoroughly around opening, including bend slots (FIG 3-A). Butyl Tape (1"x1/8") may be substituted for caulking material.
 8. Push unit against caulking, secure 4-corner brackets FIG 4-A to coach with No.8 - 3/4" round head screws (not furnished) or equivalent. Complete the installation by inserting the same type of #8 screws in the holes provided around the flange of the water heater housing.
 9. Attach access door (FIG 5).
 - a. Snap hinge pin (FIG 5-A) into clip (FIG 5-B).
 - b. Slide cover (FIG 5-C) onto hinge pin.
 - c. Slide hinge pin into cover, snapping into clip at same time (FIG 5-D).
- NOTE: To remove hinge pin, support access cover and apply force to corner of hinge pin as shown FIG 5-E.
10. Disconnect unit and its individual shut-off valve from gas supply line during any pressure testing of system in excess of 1/2 PSIG (3.4 kPa, 14" water column [W.C.]). DO NOT set inlet pressure higher than maximum indicated on rating plate of gas valve (13" W.C.). Isolate unit from gas supply line by closing its individual manual shutoff valve during any pressure testing \leq 1/2 psig.

WARNING

FIRE AND/OR EXPLOSION

- DO NOT use matches, candles or other sources of ignition when checking for gas leaks.

11. Turn on gas and check water heater and all connections for gas leaks with leak detecting solution.
12. Fill water heater tank, check all connections for water leaks (FIG 1-A & B).

PRESSURE-TEMPERATURE RELIEF VALVE

This water heater is equipped with a temperature and pressure relief valve (FIG 10) that complies with standard for Relief Valves and Automatic Gas Shutoff Devices for Hot Water Systems, ANSI Z21.22. **This valve is a safety component and must not be removed for any reason other than replacement.**

WARNING

EXPLOSION

- DO NOT place a valve, plug or reducing coupling on outlet part of relief valve.

If you use a discharge line, do not use a reducing coupling or other restriction smaller than outlet of relief valve. Allow complete drainage of both valve and line.

FOR REPLACEMENT PARTS:

- DO NOT install anything less than a combination temperature-pressure relief valve certified by a nationally recognized testing laboratory that maintains periodic inspection of product of listed equipment or materials, as meeting requirements for Relief Valves and Automatic Gas Shutoff Devices for Hot Water Supply Systems, ANSI Z21.22. Valve must have a maximum set pressure not to exceed 150 psi.
- Install valve into opening provided and marked for this purpose on water heater.
- Installation must conform with local codes or in the absence of local codes, American National Standard for Recreational Vehicles, ANSI A119.2/NFPA 501C.
- For an external electrical source, ground this unit in accordance with National Electrical Code ANSI/NFPA70.

Your Atwood gas water heater is now ready for operation. Continue to **HOW TO OPERATE YOUR WATER HEATER.**

Electronic Ignition continue to **Electronic Ignition WIRING INSTRUCTIONS.**
Pilot Relight continue to **Pilot Relight WIRING INSTRUCTIONS.**

For **HEAT EXCHANGE** continue —

1. Push 5/8" dia. 2 or 3 coolant system hose with SAE 053 A Type "E" clamp attached (FIG 6-E) onto heat exchange tube as far as possible (FIG 6-B).
2. Spread hose clamp and slide toward heat exchange unit past annular groove (FIG 6-C) and release.
3. Continue to **HOW TO OPERATE YOUR WATER HEATER** and/or **Electronic Ignition OPERATION**.

For **COMBINATION GAS/ELECTRIC MODELS** continue —

This water heater is designed to operate with gas, electricity, or a combination of both.

Provide adequate clearance at rear of unit for service of water connections and operation of manually re-settable high temperature limit switch on combination gas/electric units.

1. Follow **GENERAL INSTALLATION** instructions.

NOTE: All wiring must comply with applicable electrical codes.

- Use electrical metallic tubing, flexible metal conduit, metal clad cable, or nonmetallic-sheathed cable with grounding conductor. Wire must have a capacity of 1500 watts or greater. The wiring method must conform to applicable sections of article 551 of National Electrical Code ANSI/NFPA 70.
2. Refer to Wiring Diagram. Make 120 VAC electrical connections from junction box on back of unit.
 - a. Connect hot lead to (1) Black.
 - b. Connect common lead to (2) White.
 - c. Connect ground wire from electrical service to (3) green ground lead in junction box 3. Place switch in "OFF" position.
- When a cord and plug connection to the power supply are used on water heater, power cord must be UL listed as suitable for damp locations, hard or extra hard usage. It must be a flexible cord such as type S, SO, ST, STO, SJ, SJT, SJTO, HS or HSO cord as described in National Electrical Code, ANSI/NFPA 70. The length of external cord to water heater, measured to face of attachment plug, shall be no less than 2 feet nor more than 6 feet. Supply cord must be a minimum of 14 AWG and attachment plug must be rated at 15 amps.



CAUTION ELECTRICAL DAMAGE

- Label all wires before disconnecting when servicing controls.
- Verify proper operation after servicing.

Operation using gas continue to **HOW TO OPERATE YOUR WATER HEATER**, electrically continue to **COMBINATION Gas/Electric OPERATION**.

ELECTRONIC IGNITION - WIRING INSTRUCTIONS

1. Install unit according to **GENERAL INSTALLATION** instructions.

NOTE: It is recommended unit be connected directly to a 12V DC battery or to filtered side of an AC/DC converter. Avoid connections to unfiltered side of an AC/DC converter whenever possible. Use a minimum of 18 gauge wire, UL and CSA listed.

Refer to **WIRING DIAGRAM**. Install remote switch in a convenient location. Position wall plate with letters up. Before making connections turn switch **OFF**. The switch is off when the button is depressed towards terminal (3).

2. Installing wires:
 - a. blue lead to switch terminal (6) on indicator light of switch
 - b. terminal (4) on indicator light of switch to negative battery terminal
 - c. green lead to negative battery terminal
 - d. brown lead on water heater to terminal (3) on switch
 - e. terminal 2 on switch to positive battery terminal.
3. Read **ELECTRONIC IGNITION OPERATION**.

PILOT RELIGHT - WIRING INSTRUCTION

1. Install unit according to **GENERAL INSTALLATION** instructions.
2. Refer to Wiring Diagram. Use 18 gauge wire, UL/CSA listed.
3. Read **PILOT & PILOT RELIGHT OPERATIONS**.

CONSUMER SAFETY WARNINGS



WARNING EXPLOSION OR FIRE

- DO NOT store or use gasoline or other flammable vapors and liquids in the vicinity of this or any other appliance.
- Should overheating occur, or gas supply fail to shut off, turn **OFF** manual gas control valve to appliance, or turn gas **OFF** at the LP tank. On **ELECTRONIC IGNITION MODEL** turn operating switch to **OFF** position and remove red wire from left hand terminal of ECO switch or turn gas **OFF** at the LP tank.
- Use with LP gas only.
- Shut off gas appliances and pilot lights when refueling.
- On **PILOT RELIGHT MODELS**, turn off the ignition module when refueling gasoline tanks or LP tanks.
- Turn gas **OFF** at the LP tank when vehicle is in motion. This disables all gas appliances and pilot lights. Gas appliances must never be operated while vehicle is in motion. Unpredictable wind currents may be created which could cause flame reversal in the burner tube, which could result in fire damage. The thermal cut off fuse could also be unnecessarily activated resulting in a complete shut-down of the water heater requiring replacement of the thermal cut off. See maintenance of electronic ignition water heaters for further explanation of the thermal cut off.
- LP tanks must be filled by a qualified gas supplier only.

HOW TO OPERATE YOUR WATER HEATER



CAUTION FIRE

- Do not smoke or have any flame near an open faucet.

If water heater has not been used for more than two weeks, hydrogen gas may form in water line. Under these conditions to reduce the risk of injury, open hot water faucet for several minutes at kitchen sink before you use any electrical appliance connected to hot water system.

If hydrogen gas is present, you will probably hear sounds like air escaping through the pipe as water begins to flow.



CAUTION SCALDING INJURY

- Do not tamper with pilot orifice.



CAUTION PRODUCT FAILURE

- Do not operate without water in tank.

PILOT OPERATION

1. Turn gas control valve knob (FIG 7-B or FIG 8-B) to **OFF** position.
2. Wait at least five minutes to allow accumulated gas in burner compartment to escape.
3. Water heater may be equipped with a White Rodgers® or Robertshaw Unitrol® Control.

FOR WHITE RODGERS® CONTROL (FIG 7)

- a. Turn lighting control knob (FIG 7-B) to **PILOT** position and hold against stop while lighting pilot burner (FIG 9-D).
- b. Allow pilot to burn thirty seconds then release lighting control knob.
- c. Turn lighting control knob (FIG 7-B) to **ON** position.
- d. If pilot does not remain lit, repeat operation allowing longer period before releasing lighting control knob.
- e. Set temperature selection lever (FIG 7-A) at mark between warm and hot position.
- f. Close access door.

FOR A ROBERTSHAW UNITROL® (FIG 8)

- a. Turn lighting control dial (FIG 8-B) to **PILOT** position.
 - b. Depress and hold reset push button (FIG 8-A) while lighting pilot burner (FIG 9-D).
 - c. Allow pilot to burn thirty seconds before releasing reset push button.
 - d. If pilot does not remain lit, repeat operation allowing longer period before releasing reset push button.
 - e. Turn lighting control dial (FIG 8-B) to **ON** position.
 - f. Set temperature control dial (FIG 8-C) at mid-point position between warm and hot.
 - g. Close access door.
4. For complete shut down and before servicing, turn gas control knob (FIG 7-B or FIG 8-B) to **OFF** position. When water heater is not in use set temperature control lever (White Rogers®) or dial (Robertshaw®) to lowest possible position.



CAUTION SCALDING INJURY

- Setting temperature control dial at a higher position will produce excessively hot water.

The temperature knob or lever is factory adjusted to its lowest dial setting. We recommended the mid-point position between warm and hot, as noted above. This will provide for energy efficient operation and sufficient hot water. Valves for reducing point of use temperature by mixing cold and hot water are available. Consult a licensed plumber or local plumbing authority.

5. To Adjust Main Burner (FIG 9):
1. Loosen air shutter screw (FIG 9-A).
 2. Slide air shutter (FIG 9-B) to right until some yellow appears in main burner flame.
 3. Move air shutter (FIG 9-B) to left until yellow disappears.
 4. Retighten air shutter screw (FIG 9-A).

Read **MAINTENANCE AND CARE INSTRUCTIONS**

ELECTRONIC IGNITION OPERATION

1. Refer to **WIRING DIAGRAM**. Place remote switch in **ON** position.
2. If remote switch light stays on longer than 15 seconds, place remote switch in **OFF** position and wait 5 minutes.
3. Repeat step one.
4. For complete shut-down and before servicing:
 - a. Place remote switch in **OFF** position.
 - b. Remove red wire from left hand terminal of ECO switch (ECO to valve).
5. If heater fails to operate due to high water temperature, a lockout condition occurs (indicator light on). After water cools, reset switch in **OFF** position for at least 30 seconds, then turn to **ON** position.
6. If a lockout condition persists contact an Atwood Service Center.

Read **MAINTENANCE AND CARE INSTRUCTIONS & ELECTRONIC IGNITION MAINTENANCE**

PILOT RELIGHT OPERATION

1. Turn the switch located on the spark module to the **ON** position.
2. Read **PILOT OPERATION** instructions.
3. For complete shut down, turn lighting control knob on thermostat and spark module switch to the **OFF** position.

Read **MAINTENANCE AND CARE INSTRUCTIONS**

COMBO gas/electric ELECTRIC OPERATION

1. For gas operation refer to **Pilot, Pilot Relight or Electronic Ignition OPERATION** section (as applicable).
 2. For electrical operation use switch at the rear of water heater.
 3. Completely fill tank with water.
 4. Turn switch **ON** (FIG 11-B) (located at rear of water heater).
- NOTE: Turning power on to heater without water covering heating element may burn out element and void warranty.
5. Check for proper operation. Water temperature is set at 140°F (60°C).
 6. If the manual reset high temperature limit switch should operate, reset switch (FIG 11-A) by depressing with pencil or other nonmetallic object. If still experiencing problems contact an authorized Atwood Service Center or Atwood Service Department.

Read **MAINTENANCE AND CARE INSTRUCTIONS**.

MAINTENANCE AND CARE INSTRUCTIONS

SERVICE CALLS & QUESTIONS

Location and phone numbers of qualified Service Centers can be found at our website <http://www.atwoodmobile.com> or call 815-877-5700 to have a Service Center List mailed.



WARNING FIRE OR EXPLOSION

- Shut off gas supply at LP container before disconnecting a gas line.
- Keep control compartment clean and free of gasoline, combustible material, and flammable liquids and vapors.

AFTERMARKET WATER HEATING ELEMENT DEVICES



WARNING EXPLOSION / BURN INJURY

- DO NOT alter water heater, it will void warranty.
- DO NOT USE Aftermarket heating elements, they can lack critical safety controls.
- Use of Aftermarket heating elements can lead to an out of control heating of water tank and a catastrophic wet side explosion.

The use of manufacturer's aftermarket heating element devices may also result in damage to components or water heater. Atwood's written warranty states - "failure or damage resulting from any alteration to our water heater is the owner's responsibility". Any alteration, like the addition of an aftermarket heating element device, will void the warranty.

GENERAL INFORMATION

- LP and Water system must be turned on.
- Have gas pressure tested periodically. Should be set at 11 inches of water column with three appliances running.
- Drain water heater at regular intervals (at least one time during the year).
- Drain water heater before storing RV for the winter or when the possibility of freezing exists.
- Keep vent and combustion air grill clear of any obstructions.
- Periodically, compare flame of main and pilot burners with FIG 9 and main burner adjustments in **HOW TO OPERATE YOUR WATER HEATER**.
- When water heater is not in use set temperature control lever (White Rogers) or dial (Robertshaw) to lowest possible position. This will reduce the effects of low outdoor temperatures on calibration of temperature control mechanism.

ELECTRONIC IGNITION MAINTENANCE

- The water heater comes factory-equipped with a fused circuit board, which will protect the circuit board from wiring shorts. If the fuse should activate, the water heater will not operate. Before replacing the fuse, check for a short external to the board. Once the short is corrected, replace the 2 amp fuse with a mini ATO style fuse. Do **not** install a fuse larger than 3 amps.

- If the fuse is good and the unit is inoperative, check for excessively high voltage to the unit (more than 14 volts).
- If the previous two steps did not solve the problem, check the thermal cut-off. The thermal cutoff is a device installed in the power supply line. This device will shut off electrical power and stop heater operation when activated. For example, if an obstruction within the flue tube should occur, such as described above in the Preventative maintenance section, the burner flame/heat may contact the cutoff, resulting in a melting of the fuse element incorporated in the thermal cutoff. In order to restore power and proper operation of the water heater, the obstruction must be removed and the thermal cutoff must be replaced.

PREVENTATIVE MAINTENANCE

Spiders, mud wasps, and other insects can build nests in burner tube. This causes poor combustion, delayed ignition or ignition outside combustion tube. Listen for a change in burner sounds or in flame appearance from a hard blue flame to a soft lazy flame or one that is very yellow. These are indications of an obstruction in burner tube (FIG 9-C). Inspect and clean on a regular basis.

- Remove air shutter screw (FIG 9-A) and slide air shutter (FIG 9-B) down burner tube.
- Run a flexible wire brush down burner tube (FIG 9-C) until it is visible at end of burner tube.
- Vacuum burner where it enters combustion tube.
- Return air shutter to original position and replace screw.

HOW TO CLEAN PILOT MODELS

1. Check main burner orifice and pilot assembly for contamination (dirt, spider webs, etc.).
2. Clean main burner tube with small brush.
3. Main burner adjustment - open air shutter 1/4 way.
4. Low pilot flame. Check for contamination - if clean have the pilot orifice replaced.

HOW TO CLEAN ELECTRONIC IGNITION MODEL

1. Check main burner orifice.
2. Clean and adjust main burner.
3. Main burner and valve manifold must align with each other
4. Check electrode for cracked porcelain.
5. Check electrode for proper gap - 1/8" between electrode and ground.
6. If module board functions intermittently, remove board and clean terminal block with pencil eraser.

WATER HEATER TANK CARE

 CAUTION SCALDING INJURY
<ul style="list-style-type: none"> • Turn off water heater and allow time for water to cool before removing drain plug to flush tank.

WINTERIZING (FLUSHING) INSTRUCTIONS

1. Turn off main water supply - your pump or your water hook up source.
2. Drain water heater inner tank. Due to the location of the drain plug, approximately two quarts of water will remain in the bottom of the tank. This water contains most of the harmful corrosive particles. While draining the unit, if water flows sporadically or trickles instead of flowing steadily, we recommend one of two things. First open the relief valve to allow air into the tank and secondly, take a small gauge wire or coat hanger device and poke through drain opening to eliminate any obstructions.
3. After thoroughly draining tank, flush with air pressure or fresh water.

IF YOU USE AIR PRESSURE, it may be applied either through the inlet or outlet on rear of tank. It may also be applied through pressure temperature relief valve, but first remove pressure temperature relief valve support flange. With drain valve open, air pressure will force the remaining water along with corrosive particles out of unit.

IF YOU USE FRESH WATER, it may be pumped into the tank with the assistance of on-board pump or external water through the inlet or outlet found on rear of tank. It may also be applied through pressure temperature relief valve support located on front of unit. Continue this flushing process for approximately five minutes to allow ample time

for fresh water to agitate stagnant water on bottom of tank and force deposits through drain opening.

4. Close off drain valve as well as pressure temperature relief valve.
 5. After this procedure, there will be approximately two quarts of water left at the bottom of inner tank. Should this water freeze it will not cause any damage to the tank.
- Two or three times a year flush out tank. This may prolong the life of your tank and allow use of a full 6 gallons of hot water.

PRESSURE-TEMPERATURE RELIEF VALVE

 WARNING EXPLOSION
<ul style="list-style-type: none"> • Do not plug pressure-temperature relief valve.

Weeping or dripping of a pressure-temperature relief valve while the water heater is running DOES NOT mean it is defective.

This is normal expansion of water as it is heated in the closed water system of a recreation vehicle.

The Atwood water heater is designed with an internal air gap at the top of the tank to reduce the possibility of weeping and dripping. In time, the expanding water will absorb this air.

 CAUTION SCALDING INJURY
<ul style="list-style-type: none"> • Turn off water heater before opening pressure-temperature relief valve to establish air space. Storage water must be cool.

TO REPLACE THE AIR GAP FOLLOW THESE STEPS:

STEP 1: Turn off water heater.

STEP 2: Turn off incoming water supply.

STEP 3: Open a hot water faucet in coach.

STEP 4: Pull handle of pressure-temperature relief valve (FIG 10) straight out and allow water to flow until it stops.

STEP 5: Allow pressure-temperature relief valve to snap shut; close hot water faucet; turn on water supply.

- At least once a year manually operate pressure-temperature relief valve (FIG 10).

When pressure-temperature relief valve discharges again, repeat above procedure. For a permanent solution, we recommend one of the following:

- Install a pressure relief valve in cold water inlet line to water heater and attach a drain line from valve to outside of coach. Set to relieve at 100-125 PSI.
- Install a diaphragm-type expansion tank in cold water inlet line. Tank should be sized to allow for expansion of approximately 15 oz. of water and pre-charged to a pressure equal to water supply pressure.

These devices can be obtained from a plumbing contractor or service center.

FLUSHING TO REMOVE UNPLEASANT ODOR

Hydrogen Sulfide results when the protective cladding on the interior of the tank prevents corrosion. The electro galvanic action of the cladding material releases hydrogen from the water. If sulfur is present in the water the two will combine and produce hydrogen sulfide. This compound produces the "rotten egg odor". Hydrogen sulfide can also be present in your fresh water supply and as little as 1mg/liter can cause a perceptible odor. If your fresh water has the rotten egg odor you will need to find another source of fresh water before flushing and refilling the water storage system.

Use four parts vinegar and two parts water to flush tank.

The Atwood water heater is designed for RV's.

Flushing the water heater several times a year will prolong the life of the storage tank.

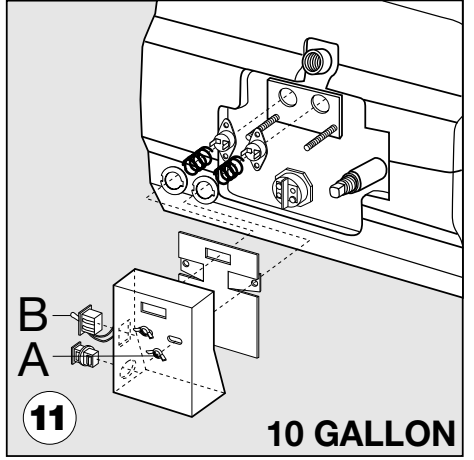
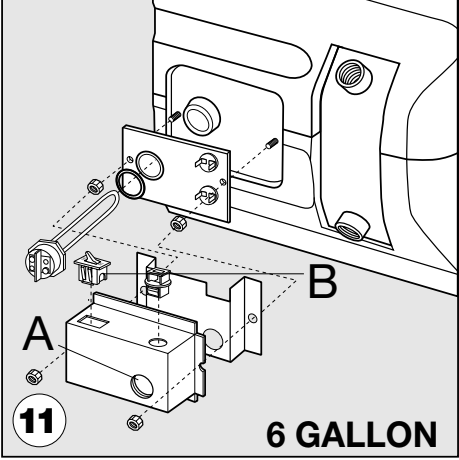
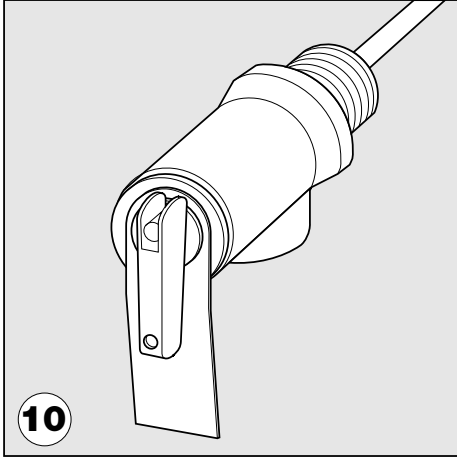
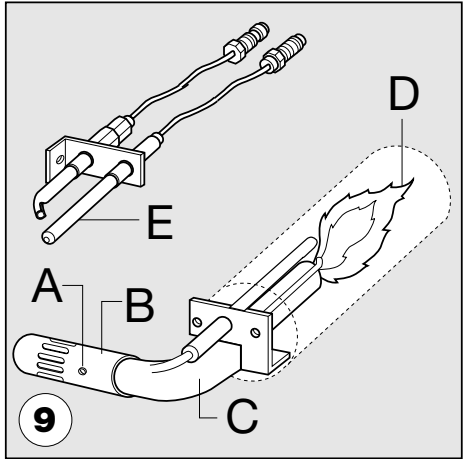
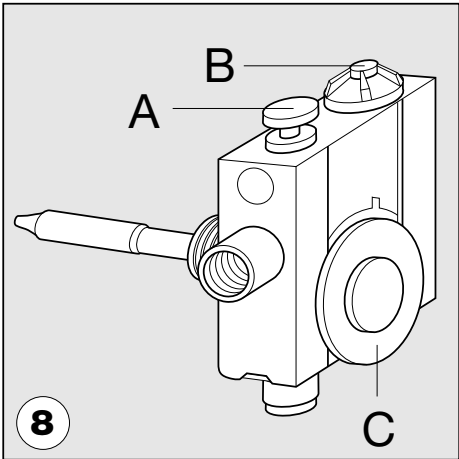
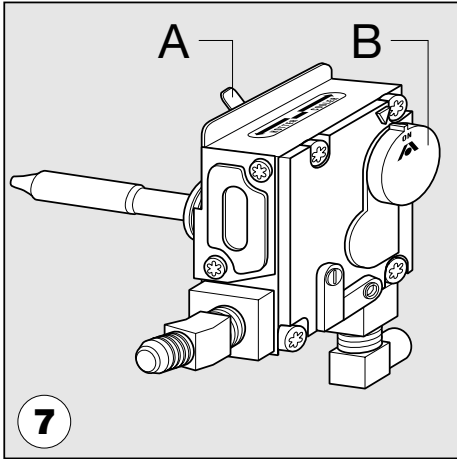
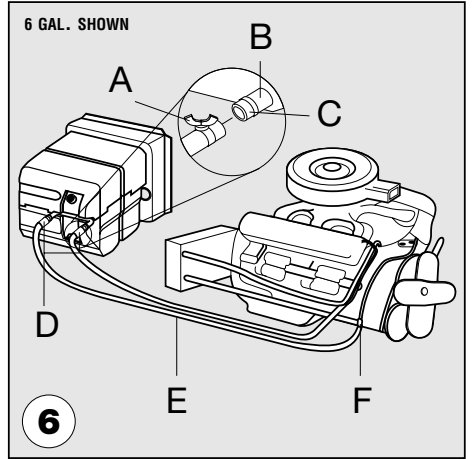
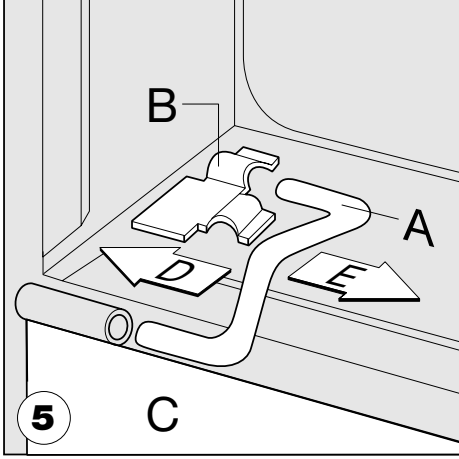
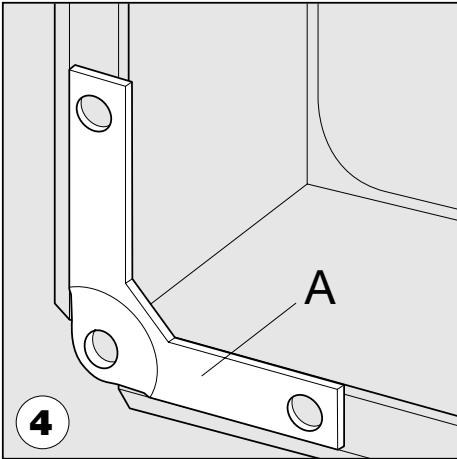
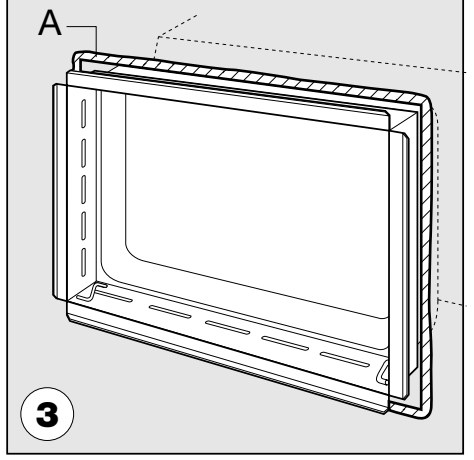
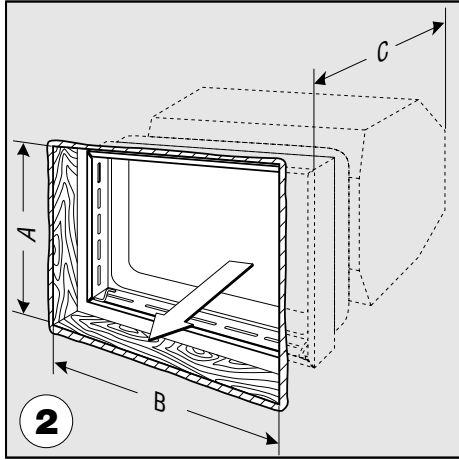
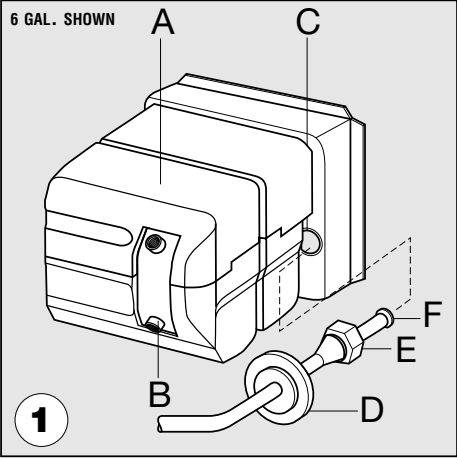

WIRING DIAGRAMS

Dotted lines are wired by customer

SPARK IGNITION

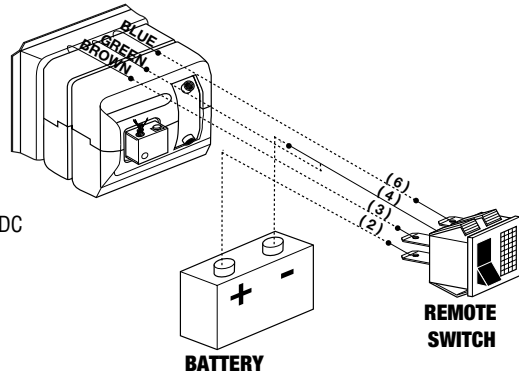
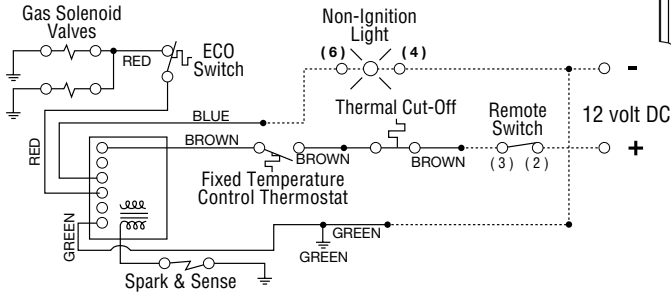

PILOT RELIGHT

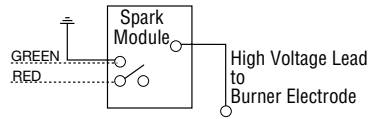

CAUTION
ELECTRICAL DAMAGE
• Label all wires before disconnecting when servicing controls.
• Verify proper operation after servicing.

COMBO gas/electric

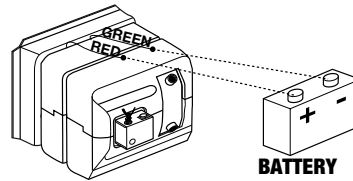
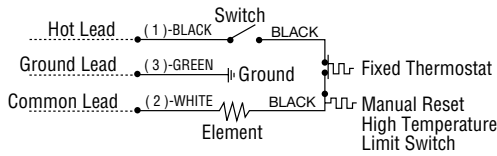

SCHÉMAS ÉLECTRIQUES

Les lignes pointillées indiquent le câblage par le client

ALLUMAGE ÉLECTRONIQUE

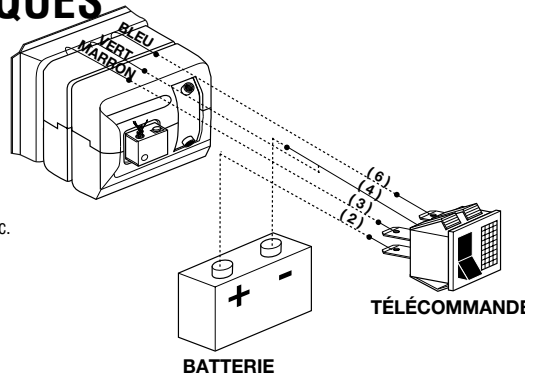
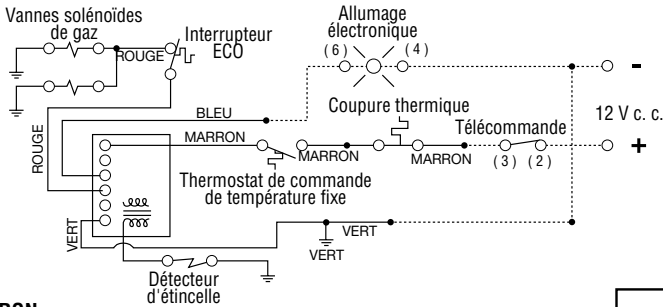

ATTENTION
Dommage électrique
• Lors de la réparation des commandes, étiqueter tous les fils avant de les déconnecter.
• Vérifier le bon fonctionnement après la réparation.

RALLUMAGE DE VEILLEUSE

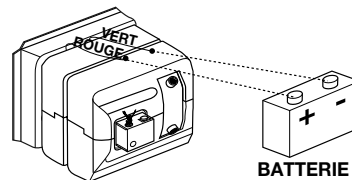
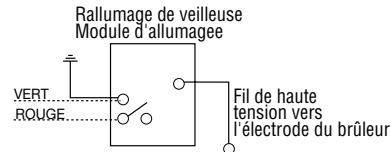

COMBINAISON gaz-électricité

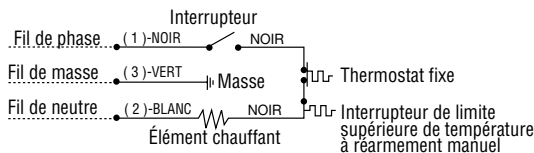

PART IDENTIFICATION IDENTIFICATION DES PIÈCES

WATER HEATER CHAUFFE-EAU
PILOT RELIGHT RALLUMAGE DE VEILLEUSE

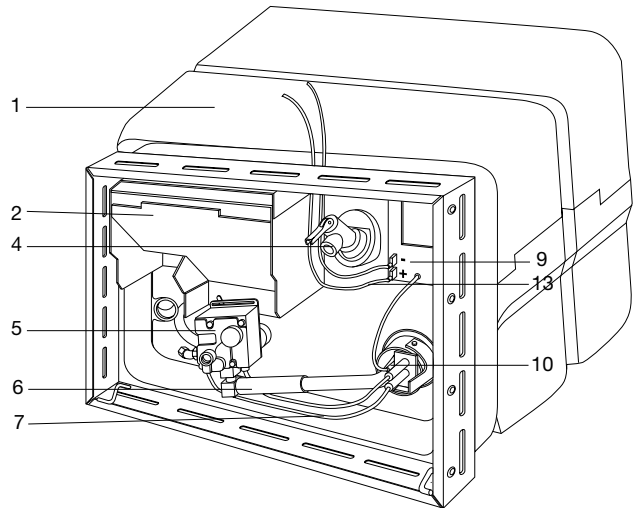
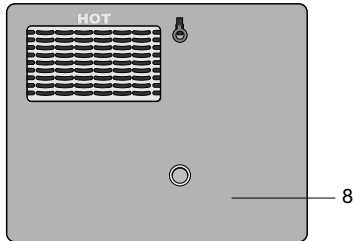

ITEM REFERENCE	6 GALLON 22 LITRES	10 GALLON 38 LITRES	PILOT IGNITION	VEILLEUSE D'ALLUMAGE
1	X	X	*Tank	Réservoir
2	90960	90960	Flue Box Assembly	Cheminée complète
3	91857	91857	Drain Plug (shown on spark ignition)	Bouchon de vidange (montré sur le modèle à allumage électronique)
4	91604	91604	Pressure-Temperature Relief Valve	Clapet de sécurité de pression température
5	91601	91601	Thermostat	Thermostat
6	92615	93221	Main Burner	Brûleur principal
7	91603	91603	Pilot Assembly	Veilleuse
8	✓	✓	Exterior Access Door	Porte d'accès extérieure
			PILOT RELIGHT	RALLUMAGE DE VEILLEUSE
9	93801	93801	Spark Module	Module d'allumage
10	93804	93804	Electrode Assembly	Électrode
13	93803	93803	Wiring Harness	Faisceau électrique

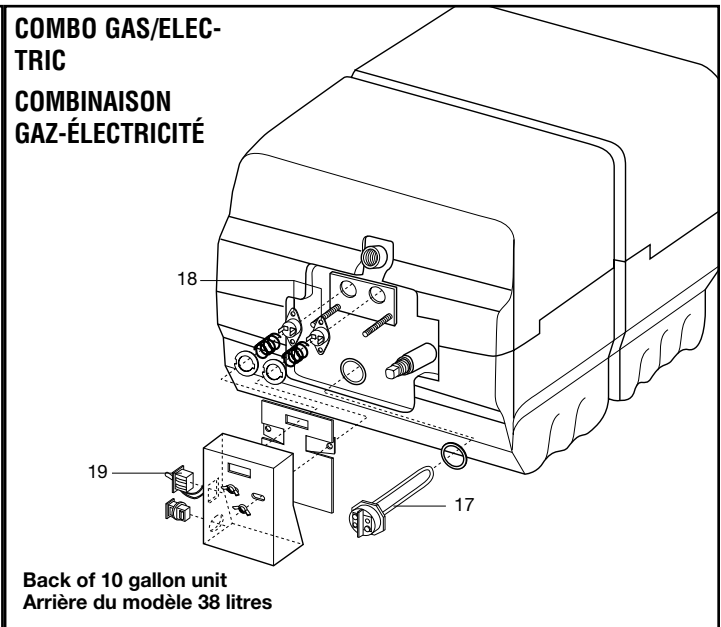
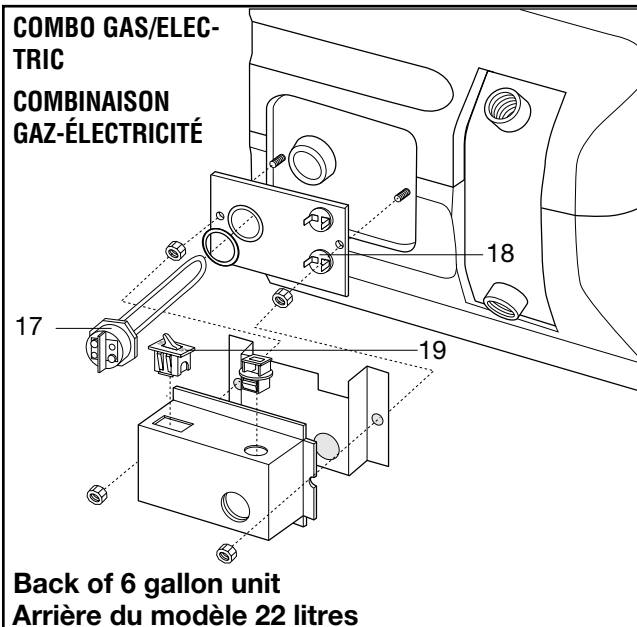

PART IDENTIFICATION IDENTIFICATION DES PIÈCES

SPARK IGNITION ALLUMAGE ÉLECTRONIQUE

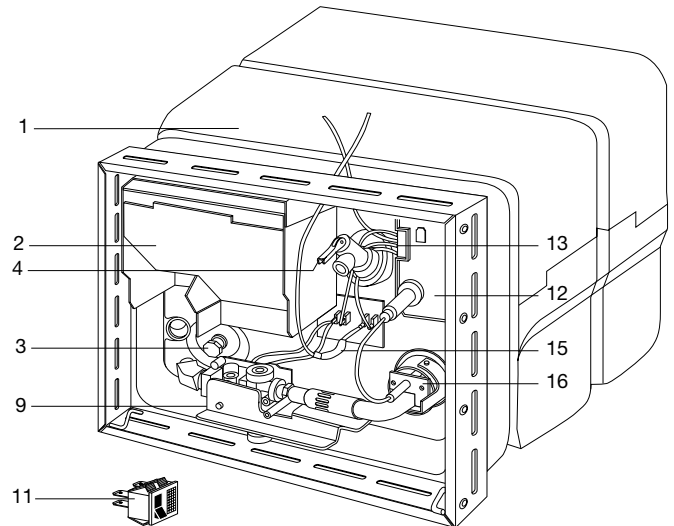
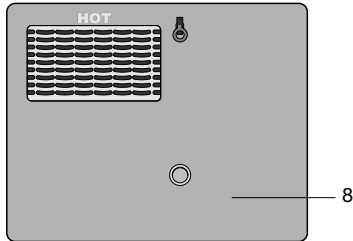

ITEM REFERENCE	6 GALLON 22 LITRES	10 GALLON 38 LITRES	SPARK IGNITION	ALLUMAGE ÉLECTRONIQUE
1	X	X	*Tank	Réservoir
2	90960	90960	Flue Box Assembly	Cheminée complète
3	91857	91857	Drain Plug	Bouchon de vidange (montré)
4	91604	91604	Pressure-Temperature Relief Valve	Clapet de sécurité de pression
9	93870	93870	Solenoid Valve	Vanne solénoïde
11	91959	91959	Black on-Off Switch	Interrupteur Marche/Arrêt
	91859	91859	White On-Off Switch	Interrupteur Marche/Arrêt
12	93865	93865	Circuit Board	Circuit imprimé
13	93189	93189	Wiring Harness	Faisceau électrique
15	93866	93866	Thermal Cut Off	Coupure thermique
16	93868	93868	Spark Probe	Détecteur d'étincelle
			HEAT EXCHANGE	ÉCHANGEUR DE CHALEUR
1	X	X	*Tank	Réservoir
			COMBINATION GAS/ELECTRIC	COMBINAISON GAZ - ÉLECTRICITÉ
1	X	X	*Tank	Réservoir
17	91160	91160	Heating Element & Gasket	Élément chauffant et joint
18	91873	91873	ECO T-Stat	Thermostat ECO
19	91092	91089	On/Off Switch	Interrupteur de Marche-Arrêt

* All tanks includes styrofoam jacket
 X Order by model
 ✓ order by color

ATWOOD WATER HEATER LIMITED WARRANTY

Atwood Mobile Products warrants to the original consumer purchaser and subject to the below mentioned conditions, that this product will be free of defects in material or workmanship for a period of two years from the original date of purchase. Atwood's liability hereunder is limited to the replacement of the product, repair of the product, or replacement of the product with a reconditioned product at the discretion of the manufacturer. This warranty is void if the product has been damaged by accident, unreasonable use, neglect, tampering or other causes not arising from defects in material workmanship. This warranty extends to the original owner of the product only and is subject to the following conditions:

1. For a period of two years from the date of purchase, Atwood will replace the complete water heater if the inner tank leaks due to corrosion. This warranty includes reasonable labor charges required to replace the complete water heater.
2. For two years from the date of purchase, Atwood will repair or replace any part defective in material or workmanship. This warranty includes reasonable labor charges, required to remove and replace the part. Service calls to customer's location are not considered part of these charges and are, therefore, the responsibility of the owner.
3. This warranty does not cover the following items classified as normal maintenance:
 - a. adjustment of gas pressure
 - b. cleaning or replacement of burner orifice
 - c. cleaning or adjustment of burner tube
 - d. cleaning or adjustment of flue
 - e. cleaning or adjustment of pilot and thermocouple
 - f. adjustment of pressure-temperature relief valve
4. **In the event of a warranty claim, the owner must contact, in advance, either an authorized Atwood Service Center or the Atwood Service Department. Warranty claim service must be**

performed at an authorized Atwood Service Center (a list will be provided at no charge) or as approved by the Consumer Service Department, Atwood Mobile Products, 4750 Hiawatha Drive, Rockford, IL 61103-1298 USA. Phone: (815-877-5700).

5. Return parts (or water heater) must be shipped to Atwood "Prepaid". Credit for shipping costs will be included with the warranty claim. The defective parts (or water heater) become the property of Atwood Mobile Products and must be returned to the Consumer Service Department, Atwood Mobile Products, 4750 Hiawatha Drive, Rockford, IL 61103-1298 USA.
6. This warranty applies only if the unit is installed according to the in-stallation instructions provided and complies with local and state codes.
7. The warranty period on replacement parts (or water heater) is the unused portion of the original warranty period.
8. Damage or failure resulting from misuse (including failure to seek proper repair service), misapplication, alterations, water damage, or freezing are the owner's responsibility.
9. Atwood does not assume responsibility for any loss of use of vehicle, loss of time, inconvenience, expense for gasoline, telephone, travel, lodging, loss or damage to personal property or revenues. Some states do not allow the exclusion or limitation of incidental or consequential damages, so the above limitations or exclusions may not apply to you.
10. Any implied warranties are limited to two (2) years. Some states do not allow limitations on how long an implied warranty lasts, so the above limitation may not apply to you. This warranty gives you specific legal rights and you may also have other rights which vary from state to state.
11. Replacement parts (components or tanks) purchased outside of the original water heater warranty carry a 90 day warranty. This includes the part at no charge and reasonable labor charges to replace it.

This Atwood heater is designed for use in recreational vehicles for the purpose of heating water as stated in the "data plate" attached to the water heater. Any other use, unless authorized in writing by the Atwood Engineering Department, voids this warranty.

6/00